

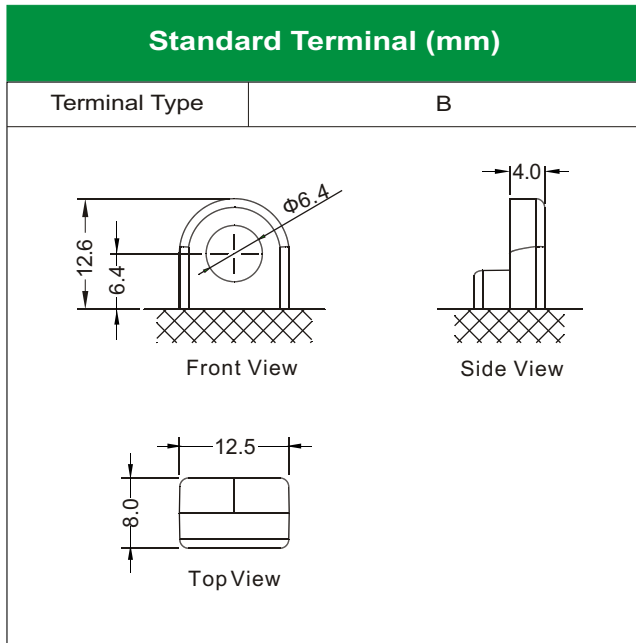

B49-6 [6V10Ah]

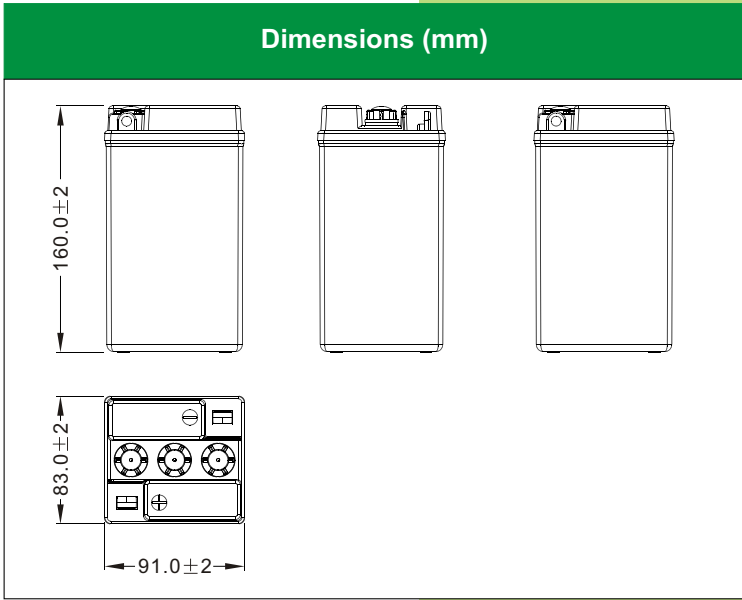

Physical Specification

Nominal Voltage		6V
Nominal Capacity (10HR)		10AH
Dimension	Length	91 ± 2mm (3.58 inches)
	Width	83 ± 2mm (3.27 inches)
	Container Height	160 ± 2mm (6.30 inches)
	Total Height (with Terminal)	160 ± 2mm (6.30 inches)
Weight	Battery(with acid): Approx 2.14kg (4.72lbs) Electrolyte: Approx 0.73kg (1.61lbs)	
<ul style="list-style-type: none"> * High performance and dry charged high quality and flooded battery * Low maintenance * Shipped without battery electrolyte pre-charged and ready to install * Replaces none battery 		

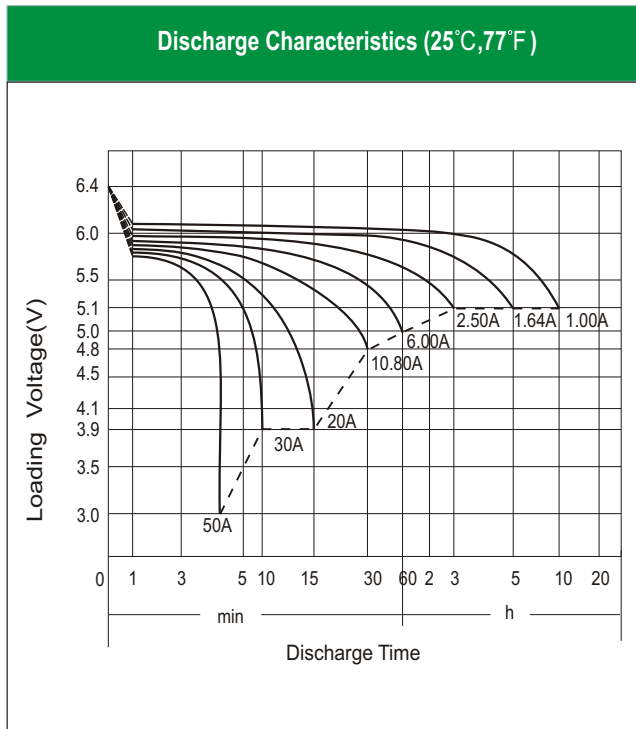

Electrical Specification

Rated Capacity	10 hour rate (1.00 A)	10.00AH
	5 hour rate (1.64 A)	8.20AH
	2 hour rate (3.50 A)	7.00AH
	1 hour rate (6.00 A)	6.00AH
	0.5 hour rate (10.80 A)	5.40AH
Capacity affected by Temperature	40 C (104 F)	106%
	25 C (77 F)	100%
	0 C (32 F)	86%
	-15 C (5 F)	65%
Self Discharge	Approximately 12% per month (25C (77F))	
Charging Methods	Full Charge	Constant-Voltage Charge: Initial charging current: less than 3.0A Voltage: 14.40 V ~ 15.00 V at 25 °C (77 °F) Charging time: 16 ~24h Constant-Current Charge: Charging current: 1.0A, when charging voltage up to 15.60V, continue to charge 2h.
	Floating Charge	No limit on Initial charging current Voltage: 13.50 V ~ 13.80 V at 25 °C (77 °F)