

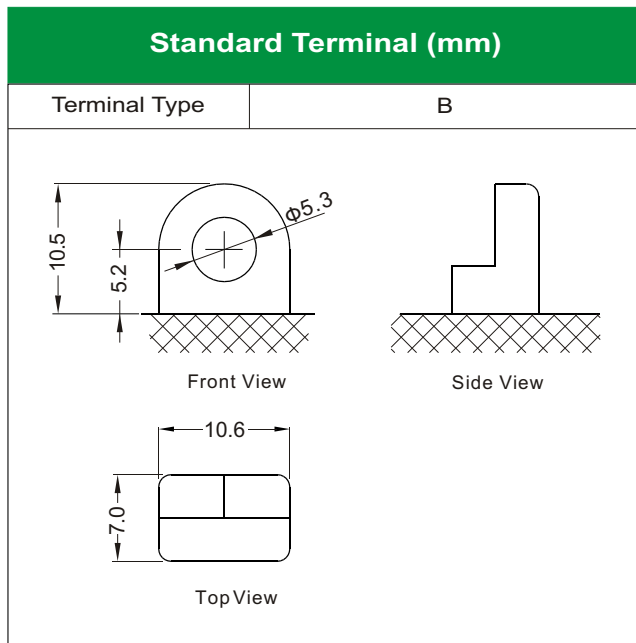

6N6-3B-1 (6V6Ah)

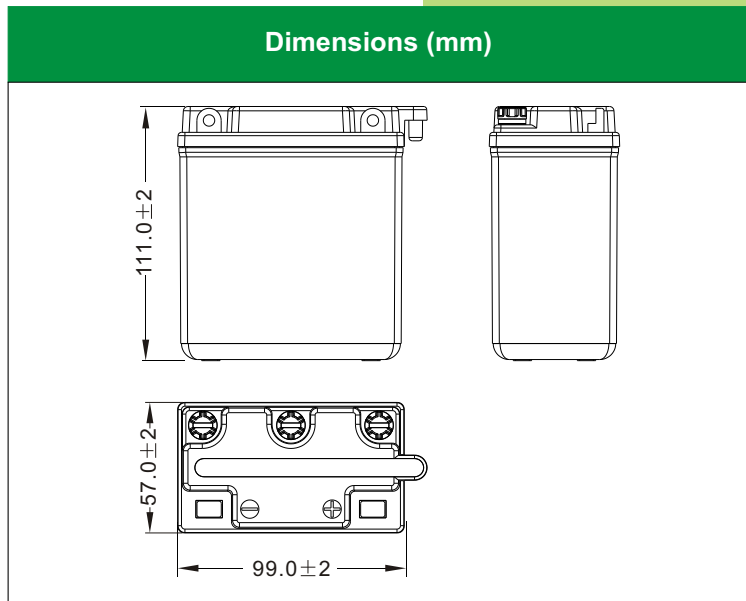

Physical Specification

Nominal Voltage		6V
Nominal Capacity (10HR)		6AH
Dimension	Length	99 ± 2mm (3.90 inches)
	Width	57 ± 2mm (2.24 inches)
	Container Height	111 ± 2mm (4.37 inches)
	Total Height (with Terminal)	111 ± 2mm (4.37 inches)
Weight	Battery(with acid): Approx 1.20kg (2.65lbs)	
	Electrolyte: Approx 0.33kg (0.73lbs)	

- * High performance and dry charged high quality and flooded battery
- * Low maintenance
- * Shipped without battery electrolyte pre-charged and ready to install
- * Replaces none battery

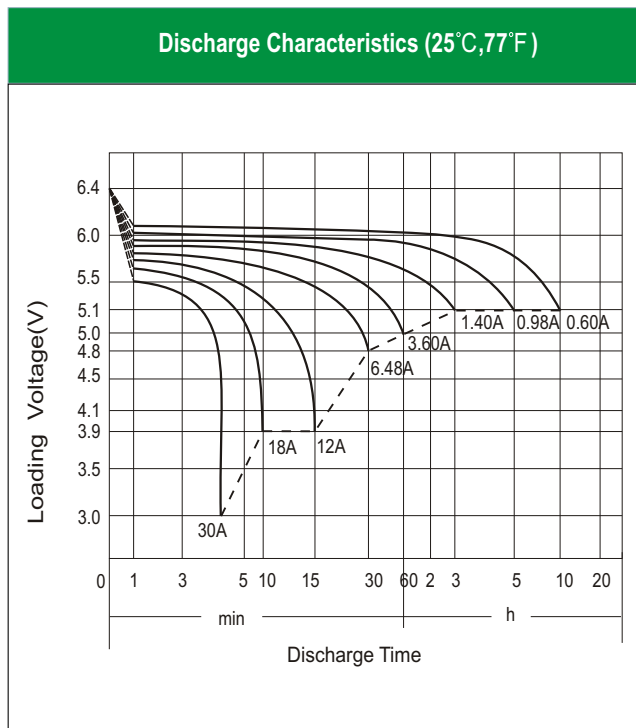

Electrical Specification

Rated Capacity	10 hour rate (0.60A)	6.00AH
	5 hour rate (0.98 A)	4.92AH
	2 hour rate (2.10 A)	4.20AH
	1 hour rate (3.60 A)	3.60AH
	0.5 hour rate (6.48 A)	3.24AH
Capacity affected by Temperature	40 C (104 F)	106%
	25 C (77 F)	100%
	0 C (32 F)	86%
	-15 C (5 F)	65%
Self Discharge	Approximately 12% per month (25C (77F))	
Charging Methods	Full Charge	Constant-Voltage Charge: Initial charging current: less than 1.8A Voltage: 7.20 V ~ 7.50 V at 25°C (77°F) Charging time: 16 ~24h Constant-Current Charge: Charging current: 0.6A, when charging voltage up to 7.80V, continue to charge 2h.
	Floating Charge	No limit on Initial charging current Voltage: 6.75 V ~ 6.90 V at 25°C (77°F)