

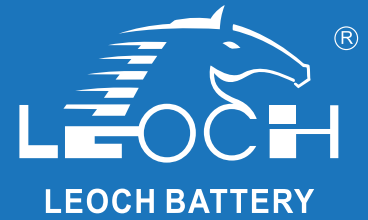

# LPCG Series-Deep Cycle Gel

## LPCG12-60(12V60Ah)



### Specifications

Rated Voltage	12V	
Nominal Capacity	60Ah	(C <sub>20</sub> , 1.80V/cell)
Dimension	Length	255±2mm (10.0 inches)
	Width	170±2mm (6.69 inches)
	Container Height	174.5±2mm (6.87 inches)
	Total Height	177.5±2mm (6.99 inches)
Approx Weight	20.2 Kg (44.5 lbs)	
Terminal	M6	
Container Material	ABS	
Rated Capacity (25°C)	60.0 Ah	(20hr, 3.00A, 1.80V/cell)
	50.0 Ah	(10hr, 5.00A, 1.80V/cell)
	47.5 Ah	(5hr, 9.50A, 1.75V/cell)
	44.1 Ah	(3hr, 14.7A, 1.75V/cell)
	34.4 Ah	(1hr, 34.4A, 1.67V/cell)
Max. Discharge Current	500A (5s)	
Internal Resistance (25°C)	Approx 8.5mΩ	
	Discharge : -20 ~ 55°C (-4 ~ 131°F)	
	Charge : 0 ~ 40°C (32 ~ 104°F)	
Operating Temp. Range	Storage : -20 ~ 50°C (-4 ~ 122°F)	
Nominal Operating Temp. Range	25±3°C (77±5°F)	
Cycle Use	Initial Charging Current less than 12.5A. Voltage 14.4V~14.7V at 25°C(77°F)Temp. Coefficient -30mV/°C	
Standby Use	Initial Charging Current less than 12.5A. Voltage 13.5V~13.8V at 25°C(77°F)Temp. Coefficient -20mV/°C	
Effect of temp. to Capacity	40°C (104°F)	103%
	25°C (77°F)	100%
	0°C (32°F)	86%
Self Discharge	LPCG series batteries may be stored for up to 9 months at 25°C(77°F) and then a freshening charge is required. For higher temperatures the time interval will be shorter.	



### Layout

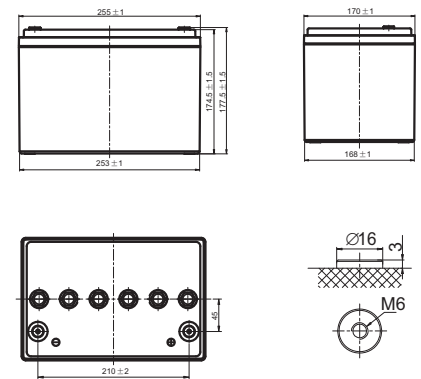

### Constant Current Discharge (Amperes) at 25 °C (77°F)

F.V/Time	1h	2h	3h	4h	5h	6h	8h	10h	20h
1.85V/cell	26.4	16.2	12.9	10.4	8.75	7.46	5.84	4.90	2.79
1.80V/cell	29.2	17.9	14.1	11.3	9.21	7.89	6.08	5.00	3.00
1.75V/cell	32.7	19.2	14.7	11.7	9.50	8.14	6.18	5.15	3.03
1.67V/cell	34.4	19.9	15.1	11.9	9.75	8.27	6.29	5.20	3.05
1.60V/cell	35.5	20.3	15.3	12.1	9.95	8.41	6.35	5.25	3.08

### Constant Power Discharge (Watts/cell) at 25 °C (77°F)

F.V/Time	1h	2h	3h	4h	5h	6h	8h	10h	20h
1.85V/cell	51.2	31.7	25.2	20.5	17.2	14.7	11.6	9.73	5.36
1.80V/cell	56.3	34.7	27.5	22.1	18.0	15.5	12.0	9.91	5.76
1.75V/cell	62.7	37.0	28.6	22.7	18.5	16.0	12.2	10.2	5.82
1.67V/cell	65.2	38.2	29.2	23.0	19.0	16.2	12.3	10.3	5.88
1.60V/cell	66.6	38.7	29.4	23.3	19.3	16.3	12.4	10.3	5.95

# LPCG Series-Deep Cycle Gel

## LPCG12-60(12V60Ah)

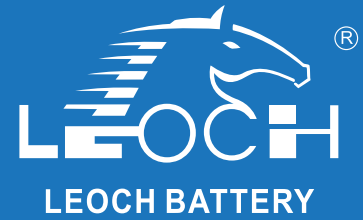

### Applications

- Electrically powered wheelchair
- Vehicle in place of walking
- Lawn-mower
- Golf trolleys and golf cart
- Railway and marine systems

### General Features

- Special plate design, long cycle life
- $\geq 600$  Cycles @ 80%DOD
- Operation temperature  $-20 \sim 55^{\circ}\text{C}$
- $\leq 2\%$  Self discharge per month
- Good deep discharge resilience performance

### Standards

- IEC 60896 Certified
- Classified as "Long Life" according to Eurobat
- UL Certified
- Manufactured in Leoch® IATF16949, ISO 9001, ISO 14001 and OHSAS 18001 certified production facilities

### Discharge Characteristics

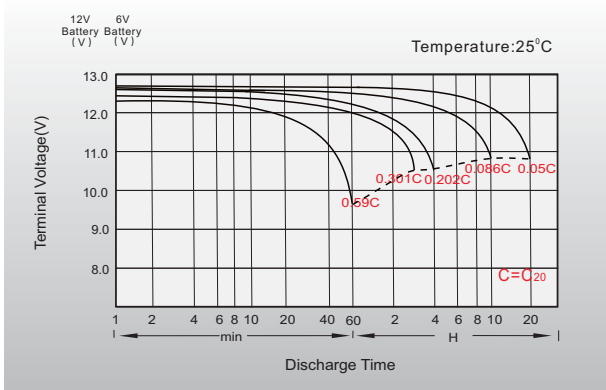

### Charging Characteristics

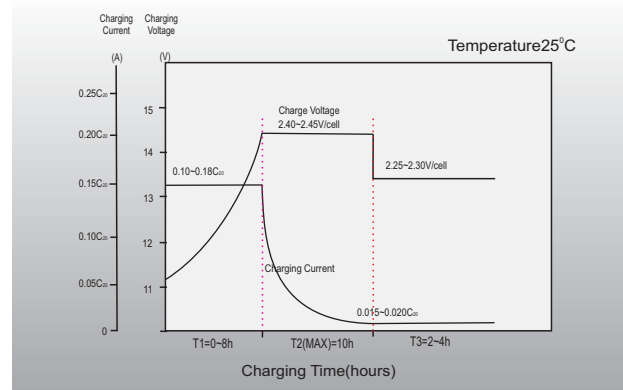

### Cycle Life in Relation to Depth of Discharge

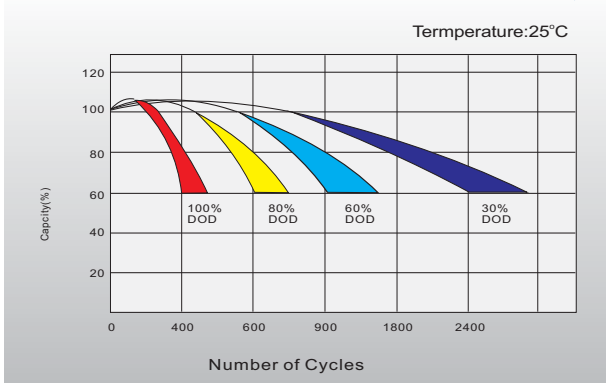

### Temperature Effects in Relation to Battery Capacity

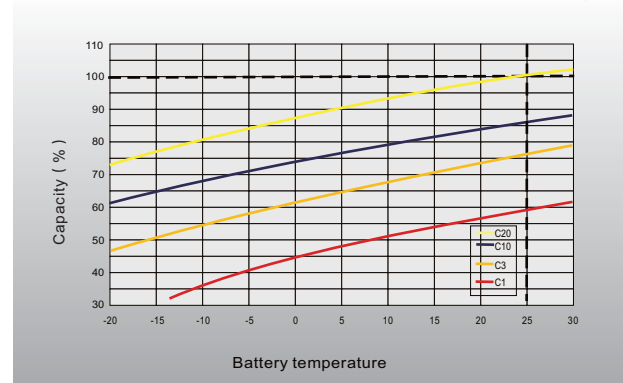

### Sales Offices Worldwide

#### China Sales Office

5th Floor, Xinbaohui Bldg., Nanhai Blvd.,  
Nanshan, Shenzhen, China. 518052  
Tel: +86-755-86036060 (100 lines)  
Fax: +86-755-26067269  
E-mail: export@leoch.com

#### HongKong Sales Office

Workshop C, 33/F, TML Tower, No. 3 Hoi Shing Road,  
Tsuen Wan, New Territories, Hong Kong  
Tel: +852 35786666  
Fax: +44 1452 690125  
E-mail: sales.hk@leoch.com

#### Singapore Sales Office

No. 1 Tech Park Crescent,  
Singapore 638131  
Tel: +65 68636078  
Fax: +65 6863 6079  
Email: sales.sg@leoch.com

#### Australia Sales Office

2 /29 Tarlington Place, Smithfield. NSW 2164  
Australia  
Tel: 02 9756 0950  
E-mail: sales.au@leoch.com

#### North America Sales Office

19751 Descartes  
Foothill Ranch, CA 92610, USA  
Tel: 949-588-5853  
Fax: 949-588-5966  
E-mail: sales@leoch.us

#### UK Sales Office

9B Wheatstone Court. Waterwells, Business Park,  
Gloucester, GL2-2AQ, UK United Kingdom  
Tel: +44(0) 1452 729428 / 1452 729696  
Fax: +44 1452 690125  
E-mail: Sales.Europe@leoch.com

#### EMEA Sales Office

1 Deligiorgi St., 121 31 Athens,  
Greece  
Tel: +30 210 5760318 (2 lines)  
E-mail: support\_EMEA@leoch.com

#### India Sales Office

Shed no.A-53(b), 2nd Stage of Peenya Industrial Area,  
Bangalore North Taluk, Bangalore-560058, India  
Tel: +91-80-23440018/23440019  
Fax: +91-80-23440017  
E-mail: indiasales@leoch.com



<http://www.leoch.com>  
<http://www.leoch.us>

© 2019 LEOCH. All rights reserved.  
Trademarks and logos are the property of LEOCH and its affiliates unless otherwise noted.  
Subject to revisions without prior notice.

Publication No.:LB-LPCG12-60-PD-EN-V2.1-201912