

NOTES: UNLESS OTHERWISE SPECIFIED

REVISIONS			
REV	DESCRIPTION	DATE	APPROVED

1. SEE DRAWING NO. CB-00315 AND PROCEDURE P-1000 FOR ASSEMBLY AND TEST INSTRUCTION. PROCEDURES AND ASSEMBLY DRAWINGS ARE FOR INTERNAL USE ONLY.
2. ALL TESTING IS PERFORMED IAW BATTERY COUNCIL INTERNATIONAL STANDARDS.
3. ALL DIMENSIONS ARE INCH [MM].

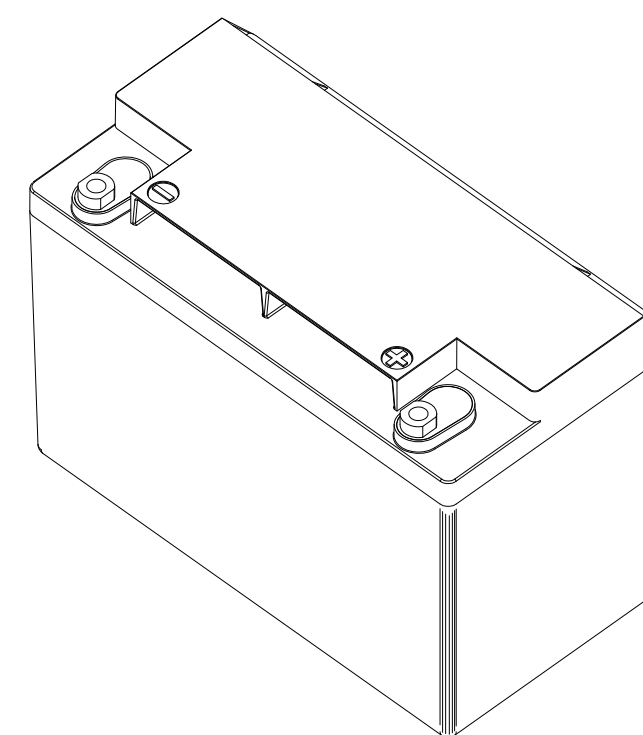
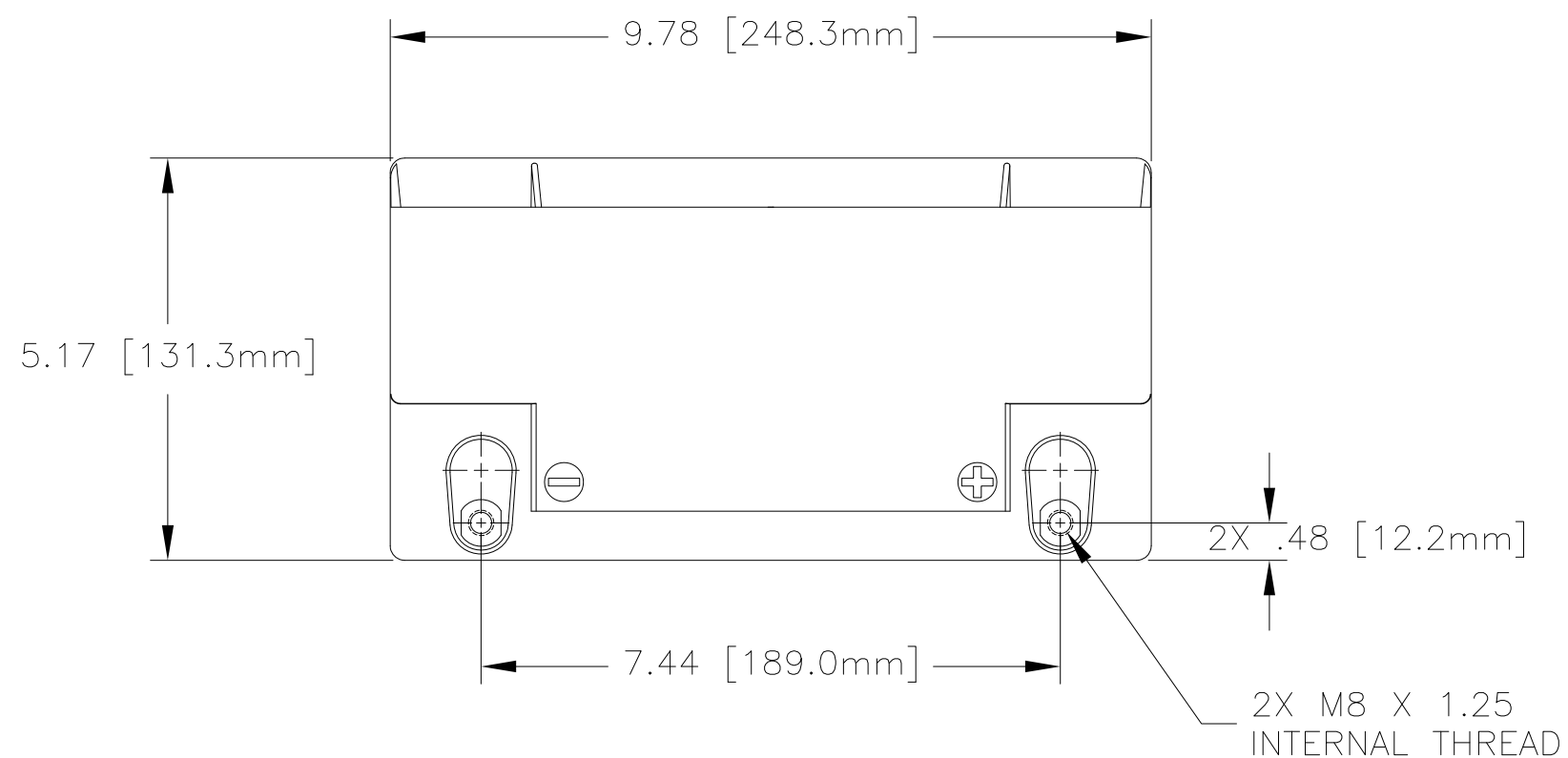

REFERENCE VIEW

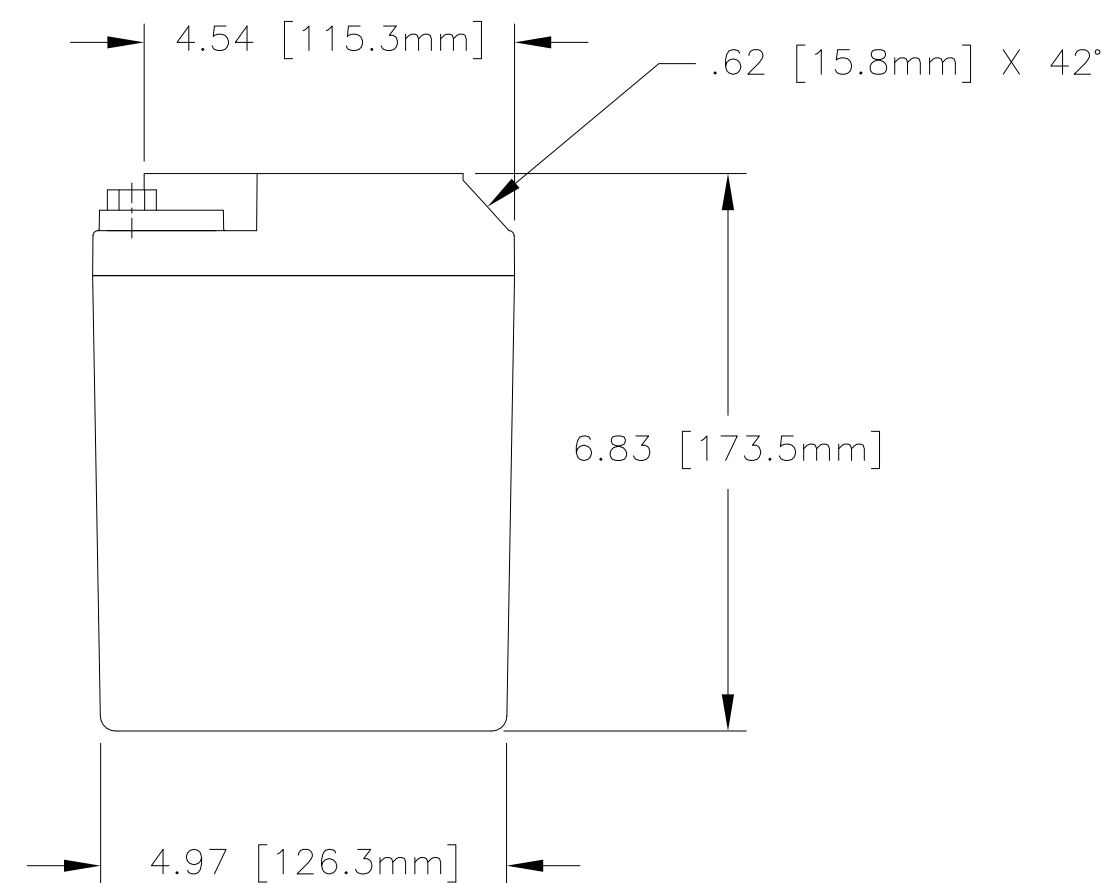
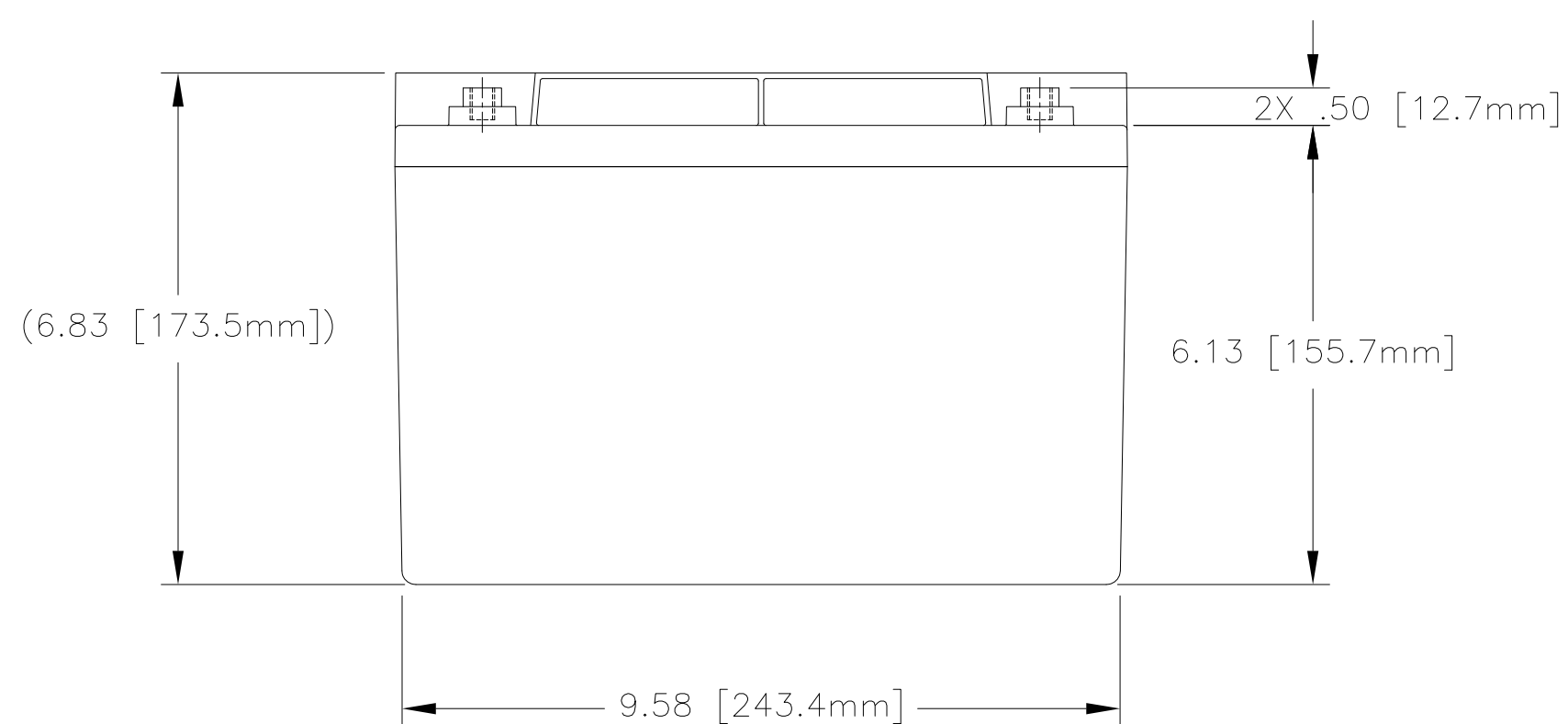

PART NUMBER	GPL-1400T
NOMINAL WEIGHT	32 LBS [14.5 KG]
AMPERE HOUR CAPACITY @ 20 HOUR 1.75 VOLTS/CELL @ 77°F (25°C)	43 AH
CRANKING Amps @ 80° F (HCA)	785
CRANKING Amps @ 32° F (CA)	685
CRANKING Amps @ 0° F (CCA)	560
RESERVE CAPACITY	90 MIN

ENVELOPE DRAWING

QTY REQD	CAGE CODE	PART OR IDENTIFYING NO.	NOMENCLATURE OR DESCRIPTION	MATERIAL SPECIFICATION	ITEM NO.
PARTS LIST					
UNLESS OTHERWISE SPECIFIED DIMENSIONS ARE IN INCHES TOLERANCES ARE:			CONCORDE BATTERY CORPORATION 2009 SAN BERNARDINO RD, W. COVINA, CA 91790		
FRACTIONS DECIMALS ANGLES .XX ± .06 .XXX ± .060			APPROVALS DATE		TITLE
TREATMENT NONE			DRAWN NS 12/8/16		BATTERY, 12 VOLT, GPL-1400T
FINISH NONE			CHECKED AMIII 12/9/16		SIZE CAGE CODE DWG NO. REV
SIMILAR TO			APPROVED PH 12/12/16		C 63017 GPL-1400T
ACT WT CALC WT			ISSUED JG 12/12/16		SCALE 1=2.5 SHEET 1 OF 1